

An RF Simulator for Enhanced Cascade System Analysis

By Dale D. Henkes, ACS

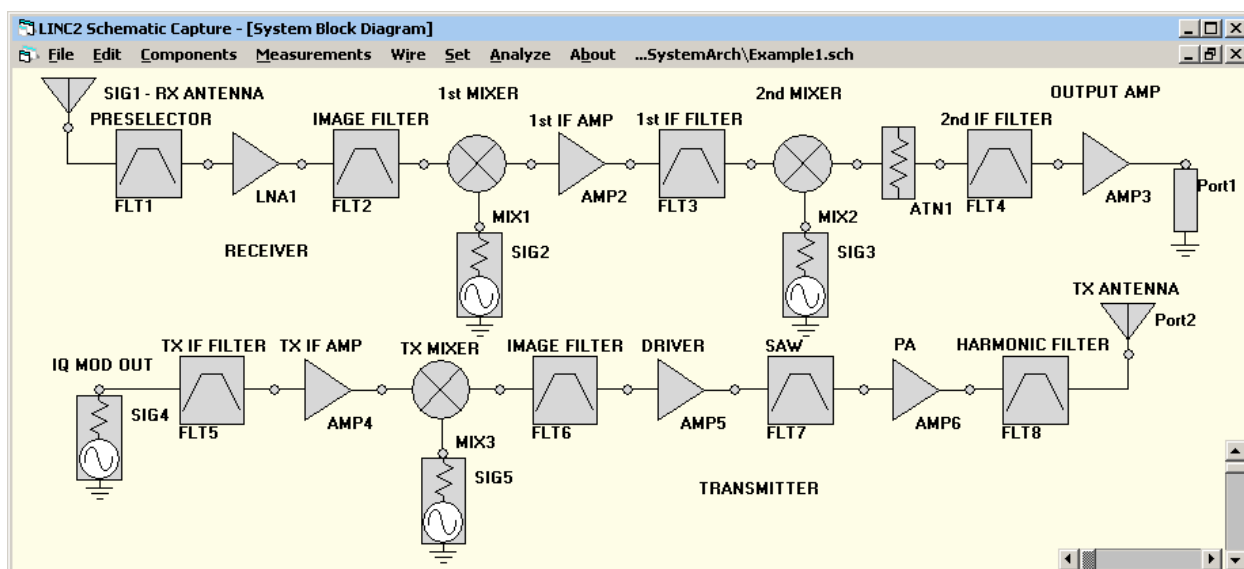

Figure 1, LINC2 VSA Block Diagram

In the design, development and production readiness qualification of RF products, the modern trend is tending to more collaboration between the “high level” systems people and the detailed circuit design engineer. Responsible for flowing down the product specifications to sub-system and circuit level specifications, the system design engineer must be cognizant of the capabilities of the available components that will make up the overall product and how these components interact. On the other hand, the circuit design engineer will likely be responsible for evaluating tradeoffs made at the circuit level to ensure that these design decisions will continue to satisfy the product requirements.

Thus, in recognizing the need for integrating both circuit and system level computer aided engineering (CAE) software into a single software package, ACS (Applied Computational Sciences, Escondido, CA) added the Visual System Architect (VSA) system simulator in 2009 to its LINC2 line of RF and microwave circuit synthesis and simulation tools. At that time ACS had offered circuit design automation in the form of circuit synthesis, simulation, and optimization for more than a decade with the LINC2 Pro CAE software suite. Now, with the Visual System Architect, RF and microwave circuit design can be appropriately driven by system design that connects product specifications to circuit level specifications.

The Visual System Architect from ACS offers a large variety of new design and analysis capability for designing at the system level. The program renders obsolete many of the traditional spreadsheet and system cascade calculators once used to analyze and predict system performance. The Visual System Architect adds the flexibility and ease of use of schematic based system simulation as shown in Figure 1. Schematics or system level block diagrams are quickly and easily created from a comprehensive menu of system component behavioral models such as amplifiers, filters, mixers, splitters, switches and attenuators etc.

The LINC2 VSA (Visual System Architect) schematic not only provides an easy and convenient way to enter the system component lineup but also serves as the system block diagram for all design reports and product technical documentation.

The LINC2 VSA employs a full RF simulation engine that enables the Visual System Architect to go beyond the traditional cascade budget plots to offer a much wider array of performance measurement methods and analysis tools. Included are spectrum analyzer type plots of all signals resulting from component and system linear and non-linear effects, such as harmonics and intermodulation products – even frequency translation of signals through mixers, up-converters and down-converters.

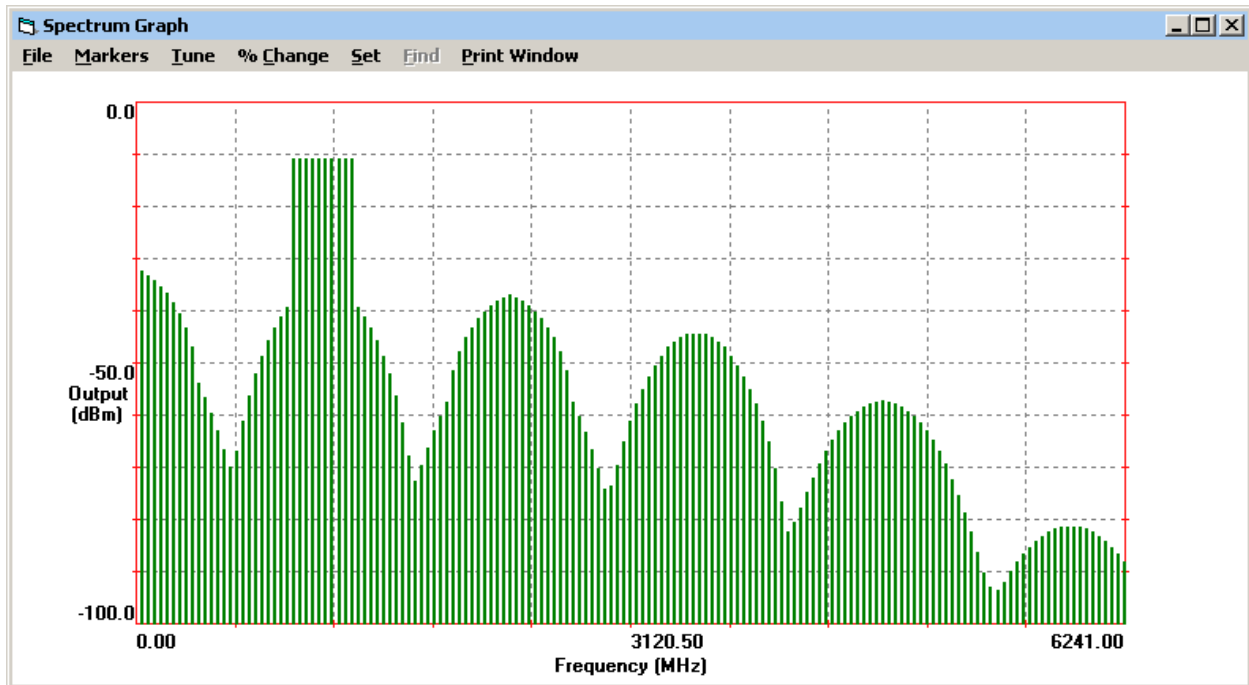

Figure 2, LINC2 VSA Spectrum Analysis Plot

Since the software employs an RF simulator it is not limited to simple one- or two-tone analysis. Figure 2 shows the spectrum analysis plot for a ten carrier multi-tone waveform after passing through the first non-linear stage of the transceiver in Figure 1. In this example, the ten CW carriers are all equal amplitude and equally spaced. However, the LINC2 VSA can simulate a system of cascaded circuit components that are driven by any arbitrary combination of signals, including excitation by any number of signals up to a maximum of 15 (ultimately limited only by PC memory) with different amplitudes, phases or frequency spacing.

But perhaps the most important benefit of using the LINC2 VSA system simulator, rather than downloading one of the many RF cascade calculators from the internet or building your own spreadsheet calculator, is accuracy. The remainder of this article will show how the typical RF chain calculator makes assumptions or approximations, particularly in calculating the P1dB compression point, which can lead to imprecise results. These issues are avoided by the LINC2 VSA simulator, precisely because LINC2 VSA is an RF simulator and not a “calculator”. LINC2 VSA actually models each component’s non-linear properties rather than simply

applying a canned formula, such as equation 1, which is the basis of most online or downloadable calculators.

$$\text{Equation 1: } P1dB = 10 * \text{Log}[(1/(P1dB_1 * G2 * G3) + 1/(P1dB_2 * G3) + 1/(P1dB_3))^{(-1)}]$$

Equation 1 is the formula typically used to calculate the 1-dB compression point for a cascade of three gain stages, where P1dB_N is the 1-dB compression point of the Nth gain stage and G2 and G3 are the linear gains of stage two and three respectively (the formula can easily be expanded to include more stages if needed). We will want to carefully consider what gain we should use in this formula.

The typical P1dB calculator uses the linear small signal gain for every single stage in equation 1. However, as we approach the P1dB point, at least one of the stages (and possibly all of them) will be in compression and therefore in a state of reduced gain. Moreover, equation 1 does not tell us how much gain compression exists at each stage so we cannot appropriately adjust the gains in equation 1.

In his book, *Practical RF System Design*, William F. Egan notes “the complexity of this process,” stating that “to predict the 1-dB compression level for a cascade, we would have to multiply (add gains in dB of) all of the transfer curves in the compression region [see Figure 4 for an example transfer curve]. We could then find the 1-dB compression level from the composite.”[1].

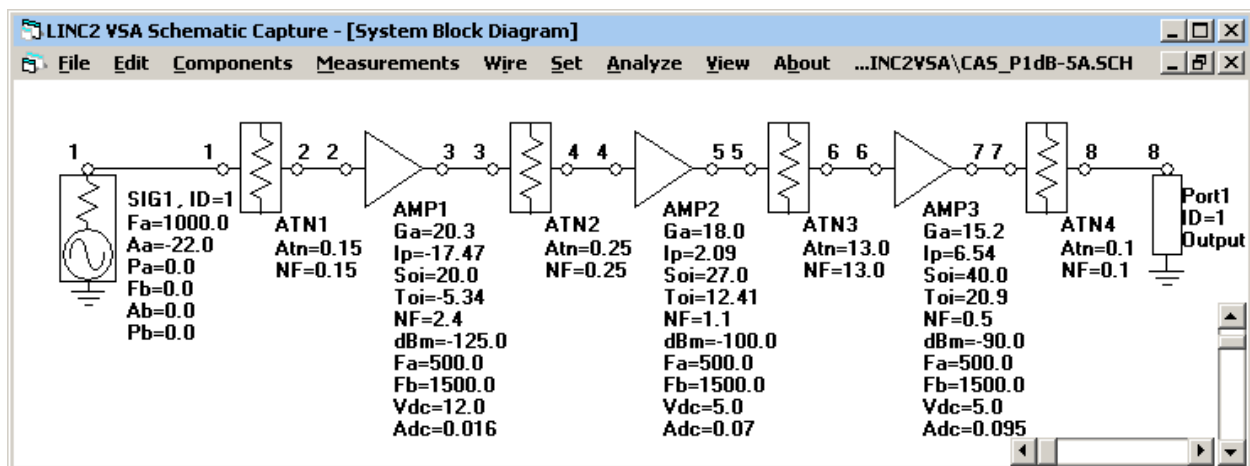

Figure 3, LINC2 VSA System Schematic

To demonstrate the ability of the LINC2 VSA simulator in predicting the P1dB compression point we configured a system of three gain stages as shown in Figure 3. The three-stage amplifier was physically constructed from modular components after measuring each amplifier stage individually for gain, P1dB and IP3 (third order intercept point). The measured component values were then entered into the LINC2 system schematic. Attenuators ATN2 and ATN3 were placed between the stages with values designed to ensure that all three amplifiers would be in compression when the overall (three-stage) amplifier was driven to its 1-dB compression point. Configuring the amplifier cascade to compress at all three stages made the P1dB prediction more challenging because no individual amplifier could be assumed to have linear small signal gain.

Figure 4 shows a LINC2 VSA power sweep simulation of the schematic in Figure 3. This Power Sweep plot graphically displays the linear range as well as the P1dB point and compression curve characteristics for the entire system cascade in Figure 3.

The LINC2 simulation results for input and output P1dB (Figure 4) were compared to the results of three different calculators obtained from the internet (one each from an educational webpage, a commercial webpage and an RF blog site). All three calculators produced identical results, indicative of using the formula in Equation 1 above. The LINC2 and online calculator results were then compared to the compression point values of the actual (physical) three-stage amplifier measured in the lab. The comparative results are shown in Table 1.

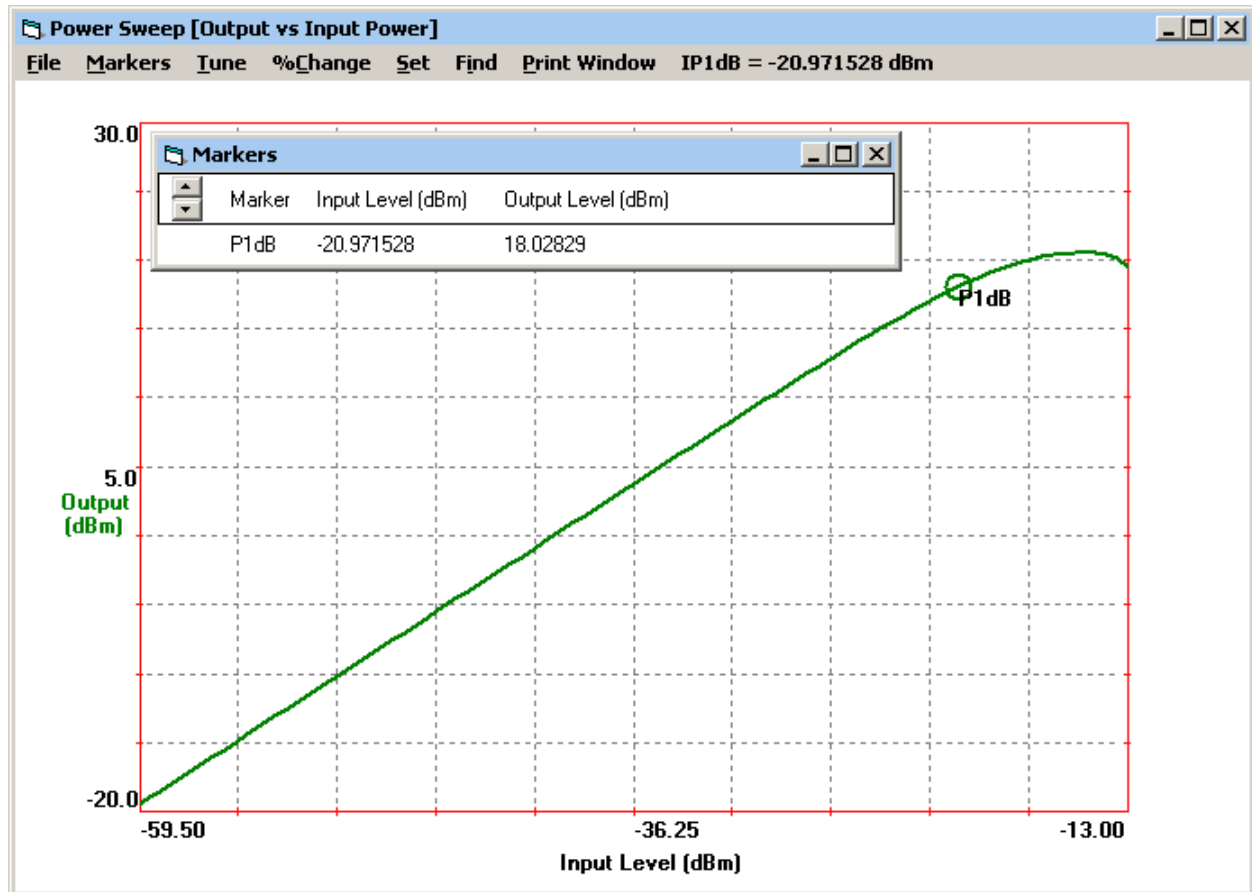

Figure 4, LINC2 VSA Power Sweep Plot

Table 1, Predicted and Measured Compression at 1 GHz

	Linear S.S. Gain (dB)	Gain at P1dB (dB)	Input P1dB (dBm)	Output P1dB (dBm)
Measured	40.6	39.6	-21.0	18.6
LINC2 VSA Sim	40.0	39.0	-20.97	18.03
Calculator 1	40.0	39.0	-22.6	16.4
Calculator 2	40.0	39.0	-22.6	16.38
Calculator 3	40.0	39.0	-22.6	16.38

Table 1 indicates that the LINC2 VSA program exactly predicted the Input P1dB at -20.97 dBm (measured -21 dBm). All three calculators predicted a P1dB level at -22.6, which is 1.6 dB lower than the actual measured value. The LINC2 VSA simulation predicted an output P1dB of 18.03 dBm or 0.57 dB below the measured value of 18.6 dBm. The output P1dB prediction of all three calculators was 2.2 dB below the measured value.

The three stage amplifier depicted in Figure 3 was constructed using a Mini-Circuits® GALI series amplifier for the first stage, while the last two stages consisted of Mini-Circuits® ZX60 series amplifiers. All measurements were performed using the Keysight® MXA N9020A signal and spectrum analyzer.

Summary and Conclusion

The Visual System Architect from ACS includes the cumulative system budget analyses that are essential to successful system design, analysis, system performance verification and report generation. Full spectral analysis provides a spectrum analyzer view of all signals and spurs at any point in the system. With the System Signal and Spur Viewer the user can trace virtually any signal or spur through the system back to its source.

System design and analysis productivity is enhanced by the flexibility and ease of use of schematic based system simulation. The ability to drag and drop circuit or system components onto the schematic page from an inclusive menu of component models allows the user to quickly construct system diagrams of nearly arbitrary topology. “What if” scenarios can quickly and easily be tested by simply dragging components into new lineup configurations.

This article demonstrated the accuracy of the LINC2 VSA program in predicting the total (cascaded) output P1dB for a three stage amplifier to within nearly a half dB of the measured value. Three other online calculators (based on the formula in Equation 1) predicted an output P1dB that fell short of the measured value by 2.2 dB or more (see Table 1). By employing an RF simulator capable of modeling the non-linear behavior of each system component, the LINC2 VSA software was able to predict the total input P1dB, in this case, to an accuracy equal to or better than the precision of the measurement equipment.

The LINC2 Software Suite

With the addition of the LINC2 Pro circuit design and simulation software suite (also from ACS), system level designs created with the Visual System Architect can proceed to the detailed circuit design level, all within a common integrated user interface.

LINC2 is a high performance RF and microwave design and simulation program from ACS. In addition to schematic based circuit simulation, optimization and statistical yield analysis, LINC2 Pro includes many value-added features for automating design tasks, including circuit synthesis.

LINC2 offers exact circuit synthesis, schematic capture, circuit simulation, circuit optimization and yield analysis in a single affordable design environment. Now, with the Visual System Architect, RF and microwave circuit design can be suitably driven by system design that

connects product specifications to circuit level specifications. The Visual System Architect software provides tuning and optimization at the system level to help ensure that a product will comply with required specifications before valuable resources are committed to detailed circuit design and prototyping.

More information about the ACS Visual System Architect and LINC2 Pro can be found on the ACS web site at www.appliedmicrowave.com.

References

[1] William F. Egan, "Compression in the Cascade", *Practical RF System Design*, Wiley, NJ, 2003, page 119.

Mini-Circuits® is a trademark of Mini-Circuits Corporation.

Keysight is trademark of Keysight Technologies, Inc.

All trademarks and registered trademarks are the property of their respective owners.